

Piezoelectric Accelerometer

**ENDEVCO
MODEL
2220E**

Model 2220E

- High Temperature (260°C)
- Miniature Design
- 360° Cable Orientation
- Hermetically Sealed
- Small-Motor Testing, APU's, Hydraulic Actuators



Actual size

DESCRIPTION

The ENDEVCO® Model 2220E is a miniature piezoelectric accelerometer designed specifically for high temperature vibration measurement on mini-structures and small objects. The unit is hermetically sealed and ideal for use in extreme environments. Its light weight (3.1 gm) effectively eliminates mass loading. The accelerometer is a self-generating device that requires no external power source for operation.

Model 2220E features Endevco's PIEZITE® Type P-8 crystal elements operating in annular shear mode. This configuration exhibits excellent output sensitivity stability over time. Signal ground is connected to the outer case of the unit. When used with the supplied isolated mounting screw assembly, the accelerometer is electrically isolated from ground. A specially designed, low-noise coaxial cable is supplied for error-free operation. The transducer utilizes a centrally located thru bolt, allowing 360° cable orientation. The unit may also be mounted with an adhesive.

ENDEVCO Signal Conditioner Models 133, 2775B, 2771B, or OASIS 2000 Computer-Controlled System are recommended for use with this high-impedance accelerometer.

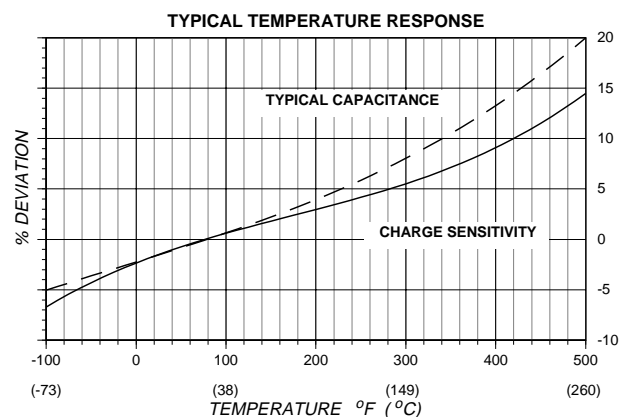
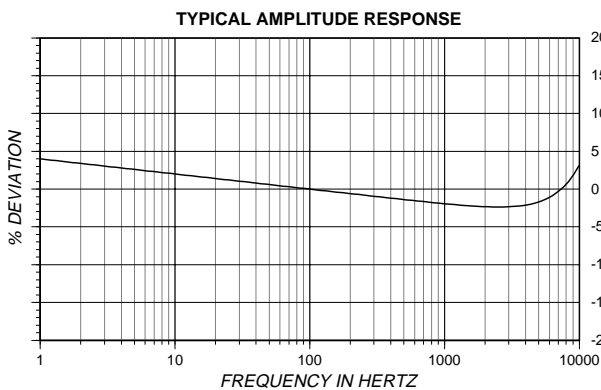
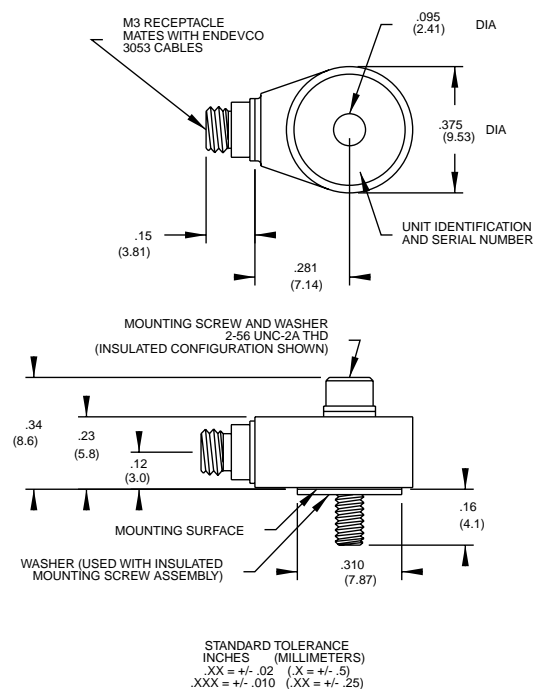

Piezoelectric Accelerometer

SPECIFICATIONS

The following performance specifications conform to ISA-RP-37.2 (1964) and are typical values, referenced at +75°F (+24°C) and 100 Hz, unless otherwise noted. Calibration data, traceable to National Institute of Standards and Technology (NIST), is supplied.

DYNAMIC CHARACTERISTICS	Units	
CHARGE SENSITIVITY		
TYPICAL	pC/g	3.0
MINIMUM	pC/g	2.0
FREQUENCY RESPONSE		See Typical Amplitude Response
RESONANCE FREQUENCY	kHz	50
AMPLITUDE RESPONSE [1]		
±5%	Hz	1 to 10 000
±1dB	Hz	.5 to 12 000
TEMPERATURE RESPONSE		See Typical Curve
TRANSVERSE SENSITIVITY	%	≤ 5
AMPLITUDE LINEARITY [2]	%	1
Per 500 g, 0 to 5000 g		

ELECTRICAL CHARACTERISTICS

OUTPUT POLARITY		Acceleration directed into the base of the unit produces positive output.
RESISTANCE	GΩ	≥ 20
CAPACITANCE	pF	650
GROUNDING		Signal return connected to case. Case isolated from mounting surface by insulated screw assembly

ENVIRONMENTAL CHARACTERISTICS

TEMPERATURE RANGE		-67°F to +500°F (-55°C to +260°C)
HUMIDITY		Hermetically Sealed
SINUSOIDAL VIBRATION LIMIT	g pk	1000
SHOCK LIMIT	g pk	5000
BASE STRAIN SENSITIVITY	equiv. g/μ strain	0.05

PHYSICAL CHARACTERISTICS

DIMENSIONS		See Outline Drawing
WEIGHT	gm (oz)	3.1 (0.11)
CASE MATERIAL		304L stainless steel
CONNECTOR		M3 x 0.5 6H thread, mates with Endevco 3053 cables
MOUNTING TORQUE	lbf-in (Nm)	5 (0.57)

CALIBRATION

SUPPLIED:		
CHARGE SENSITIVITY	pC/g	
CAPACITANCE	pF	
MAXIMUM TRANSVERSE SENSITIVITY	%	
CHARGE FREQUENCY RESPONSE	%	20 Hz to 10 000 Hz
	dB	10 kHz to 50 kHz

ACCESSORIES

EH96, EHW95	MOUNTING SCREW AND WASHER
EHM178	WRENCH
3053V-120 (10 ft)	CABLE ASSEMBLY
12746	INSULATED MOUNTING SCREW ASSEMBLY

OPTIONAL ACCESSORIES

3090DV-XXX	CABLE ASSEMBLY, EXTENSION (10-32/10-32)
EJ34	CABLE ADAPTER
2771BM1-1	IN-LINE CHARGE CONVERTER FOR USE WITH CONSTANT CURRENT SOURCE
2950M18	TRIAxIAL MOUNTING BLOCK
3053H-XXX	HYPERFLEX CABLE ASSEMBLY (M3/10-32)

NOTES

1. Low-end response of the transducer is a function of its associated electronics.
2. Short duration shock pulses, such as those generated by metal-to-metal impacts, may excite transducer resonance and cause linearity errors. Send for TP290 for more details.
3. Maintain high levels of precision and accuracy using Endevco's factory calibration services. Call Endevco's inside sales force at 800-982-6732 for recommended intervals, pricing and turn-around time for these services as well as for quotations on our standard products.

Continued product improvement necessitates that Endevco reserve the right to modify these specifications without notice. Endevco maintains a program of constant surveillance over all products to ensure a high level of reliability. This program includes attention to reliability factors during product design, the support of stringent Quality Control requirements, and compulsory corrective action procedures. These measures, together with conservative specifications have made the name Endevco synonymous with reliability.